

# OMEGA COMPRESSORS

For us, it's not just business. It's personal.

ITEM	TORQUE SPECIFICATIONS
Flywheel	[M-8] 22-24 FT/LBS
Cylinder	N/A
Bearing Seat	[M-6] 6-8 FT/LBS
Cylinder Head	[M-6] 9-11 FT/LBS

MODEL : PK-10

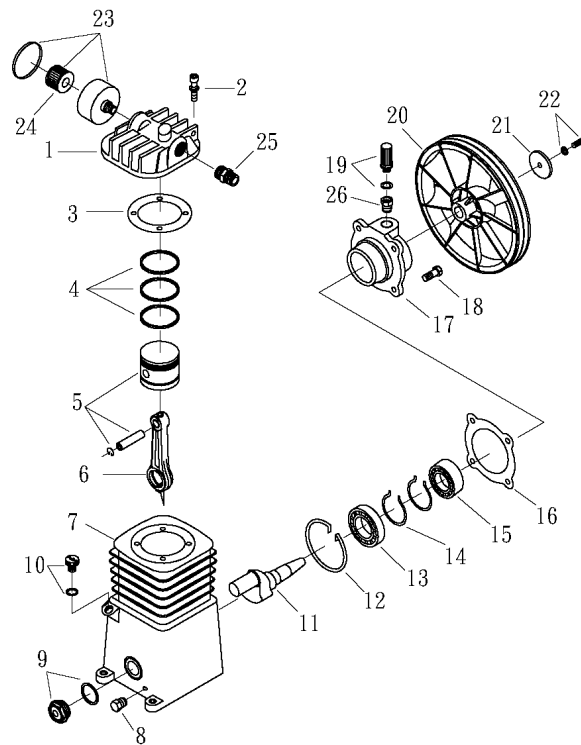

## SPARE PARTS LIST

NO : QC-1903

REF. NO.	DESCRIPTION	PART NO.	QTY.	REF. NO.	DESCRIPTION	PART NO.	QTY.
1	Cylinder head set	3B1-PP1	1	14	Crankshaft snap ring	2N42-S20	2
2	Allen bolt	3B01-M06*020V	4	15	Bearing	2N35-6003LB	1
3	Cylinder head gasket	2G01-005	1	16	Rear bearing seat gasket	2G06-009	1
4	Piston ring set	3B32-51	1	17	Rear bearing seat	3311016	1
5	Piston set	3B31-51	1	18	Hexagon bolt	2B00-SM06*020	4
6	Rod	2315013	1	19	Breathing cover	2339013A	1
7	Crankcase	3301022	1	20	Pulley	3PBF-059A120	1
8	Oil draining plug	2N33-001	1	21	Plate washer	2B30-08*26*30	1
9	Oil sight gauge set	2303013A	1	22	Hexagon bolt set	3B00-SM08*030V	1
10	Oil filling plug set	2319001A	1	23	Air filter set	2140019A	1
11	Crankshaft & balancer	3304019	1	24	Filter element	2142013	1
12	Bearing snap ring	2N43-020	1	25	Nipple	2N01-012	1
13	Bearing	2N35-6204	1	26	Bushing	2N02-040	1