

OMEGA COMPRESSORS

For us, it's not just business. It's personal.

FS-0500

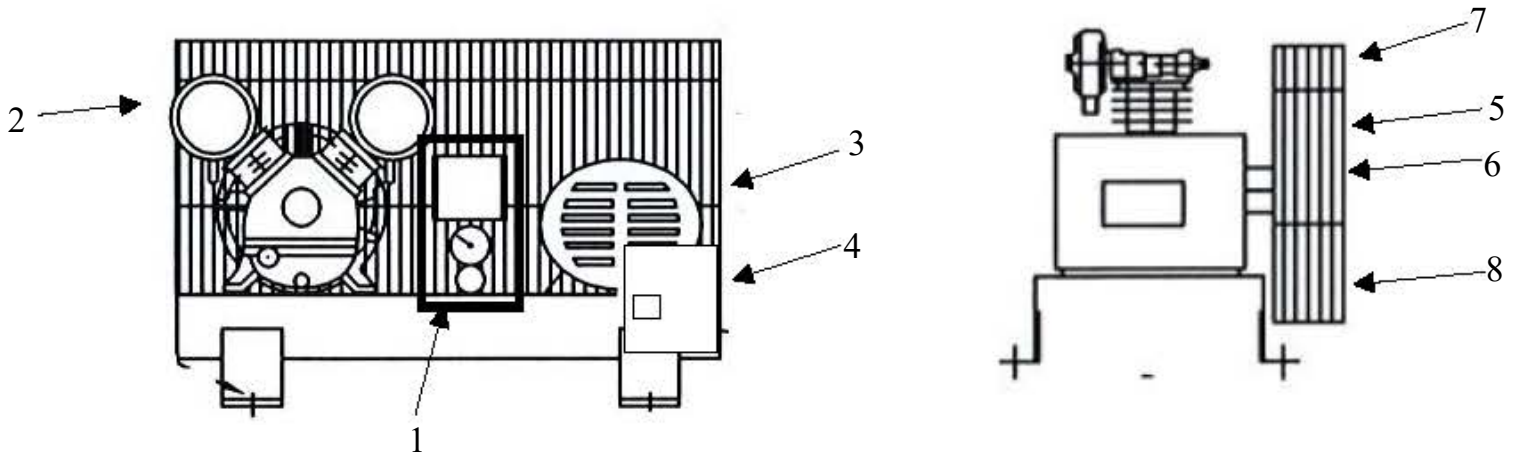

Spare Parts List

Ref. No.	Description	Part Number	Qty.
1	FS-ACG Includes: Premium Gauge Safety Valve Pressure Switch Check Valve	GAL-25B2-300 (1qty) SV25-140 (1qty) PSHD-U3050 (1qty) CV-IL50 (1qty)	1
2	Pump	PK-50	1
3	Motor	MT-05-01	1
		MT-05-02	1
		MT-05-03	1
		MT-05-04	1
		MT-05-05	1
4	Magnetic Starter	MS-05-01	1
		MS-05-02	1
		MS-05-03	1
		MS-05-04	1
		MS-05-05	1
5	Sheave/Pulley	MA30X5/8	1
6	A45 Belt	VBA45	1
7	Belt Guard	3426092	1
8	Bottom of Belt Guard	3427201	1