

# OMEGA COMPRESSORS

For us, it's not just business. It's personal.

TUK-1300GE

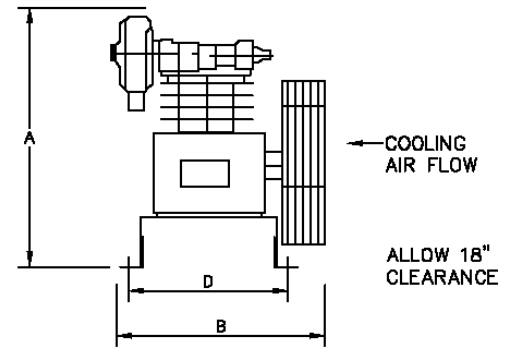
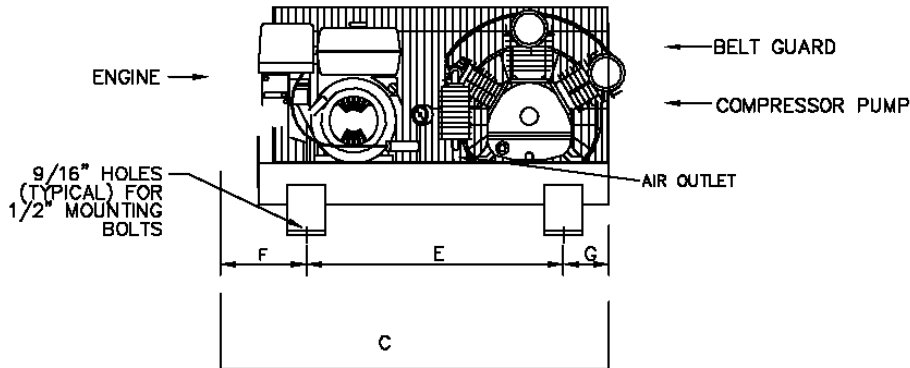

### PERFORMANCE DATA

MODEL	HP	DELIVERY		PRESSURE SETTINGS		RECEIVER		COMPRESSOR			
		SCFM	L/S	PSIG	KPA	Gal	US. LITERS	PUMP	RPM	CYL	STGS
TUK-1300GE	13	27.5	12.98	140-175	965-1207	N/A	N/A	TUK-100	630	3	1

### DIMENSIONAL DATA (inches)

MODEL	A	B	C	D	E	F	G
TUK-1300GE	31	23	46	16	23.5	9	13.5

### WT. DISTRIBUTION (Lbs)

FT.1	FT.2	FT.3	FT.4	TOTAL
143	142	142	143	570

### ELECTRICAL DATA (60Hz)

HP.	APPROX. FULL LOAD AMPS					
	Single Phase		Three Phase			
	110V.	220V.	200V.	230V.	460V.	575V.
13	N/A	N/A	N/A	N/A	N/A	N/A

BELT GUARD SIDE	
2	4
1	3

OMEGA AIR COMPRESSORS	INDUSTRIAL GAS SERIES	13HP BASE MOUNTED GAS COMPRESSOR	Print No: Dwg: Chk'd	ESJL33S-1 Scale: Not to. Wt Dist: +-5lbs
Typical only. Data & specifications may be subject to change. May not include accessory items for any particular order.			Project Reference:	