

# OMEGA COMPRESSORS

For us, it's not just business. It's personal.

TK-5080

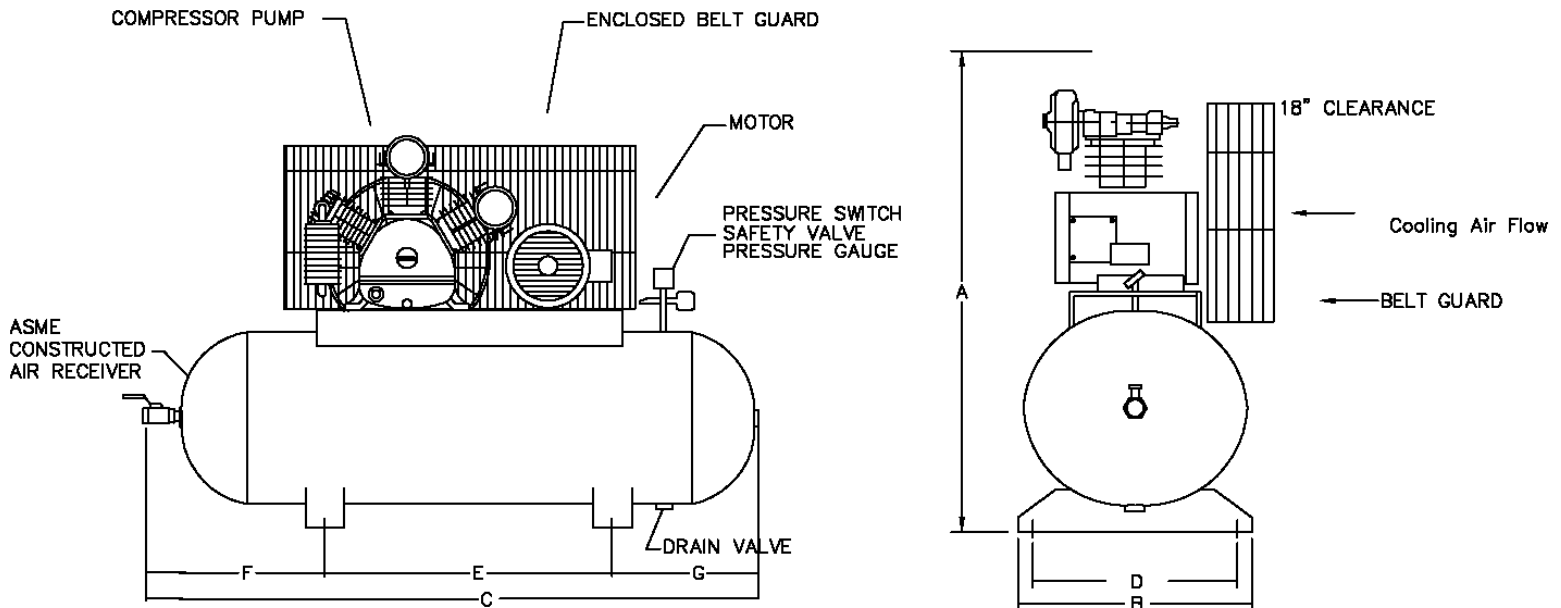

### PERFORMANCE DATA

MODEL	HP	DELIVERY		PRESSURE SETTINGS		RECEIVER		COMPRESSOR			
		SCFM	L/S	PSIG	KPA	Gal	US. LITERS	PUMP	RPM	CYL	STGS
TK-5080	5	19	8.97	120-150	828-1034	80	302	TK-50	960	V-3	2

### DIMENSIONAL DATA (inches)

MODEL	A	B	C	D	E	F	G
TK-5080	45	22	69	18.75	36	19.5	13.5

### WT. DISTRIBUTION (Lbs)

FT.1	FT.2	FT.3	FT.4	TOTAL
136	165	90	156	547

### ELECTRICAL DATA (60Hz)

HP.	APPROX. FULL LOAD AMPS					
	Single Phase		Three Phase			
	110V.	220V.	200V.	230V.	460V.	575V.
5	N/A	21.0	15.0	13.8	6.9	5.5

BELT GUARD SIDE			
2			4
1			3

OMEGA AIR COMPRESSORS	INDUSTRIAL SERIES	5 HP TANK MOUNTED SIMPLEX COMPRESSOR	Print No: Dwg: Chk'd	ESJL3SS-1 Scale: Not to. Wt Dist: +-5lbs
Typical only. Data & specifications may be subject to change. May not include accessory items for any particular order.			Project Reference:	