

# OMEGA COMPRESSORS

For us, it's not just business. It's personal.

TK-50120

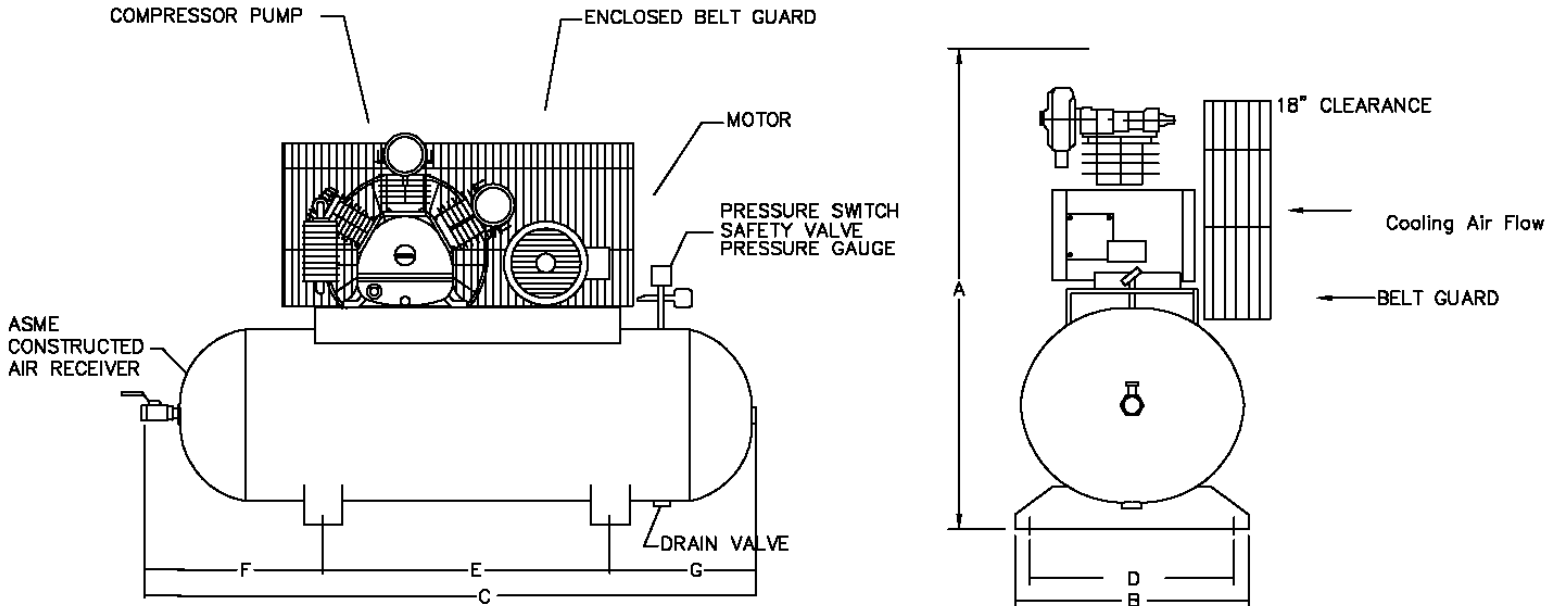

### PERFORMANCE DATA

MODEL	HP	DELIVERY		PRESSURE SETTINGS		RECEIVER		COMPRESSOR			
		SCFM	L/S	PSIG	KPA	Gal	US. LITERS	PUMP	RPM	CYL	STGS
TK-50120	5	19.1	8.97	120-150	828-1034	120	454	TK-50	960	V-3	2

### DIMENSIONAL DATA (inches)

MODEL	A	B	C	D	E	F	G
TK-50120	49	27	75	23.75	42	19.5	13.5

### WT. DISTRIBUTION (Lbs)

FT.1	FT.2	FT.3	FT.4	TOTAL
164	199	108	189	660

### ELECTRICAL DATA (60Hz)

HP.	APPROX. FULL LOAD AMPS					
	Single Phase		Three Phase			
	110V.	220V.	200V.	230V.	460V.	575V.
5	N/A	21.0	15.0	13.8	6.9	5.5

BELT GUARD SIDE	
2	4
1	3

<b>OMEGA AIR COMPRESSORS</b>	<b>INDUSTRIAL SERIES</b>	<b>5HP TANK MOUNTED SIMPLEX COMPRESSOR</b>	Print No: Dwg: Chk'd	<b>ESJL39S-1</b> Scale: Not to. Wt Dist: +-5lbs
Typical only. Data & specifications may be subject to change. May not include accessory items for any particular order.			Project Reference:	