

OMEGA COMPRESSORS

For us, it's not just business. It's personal.

TK-10080V

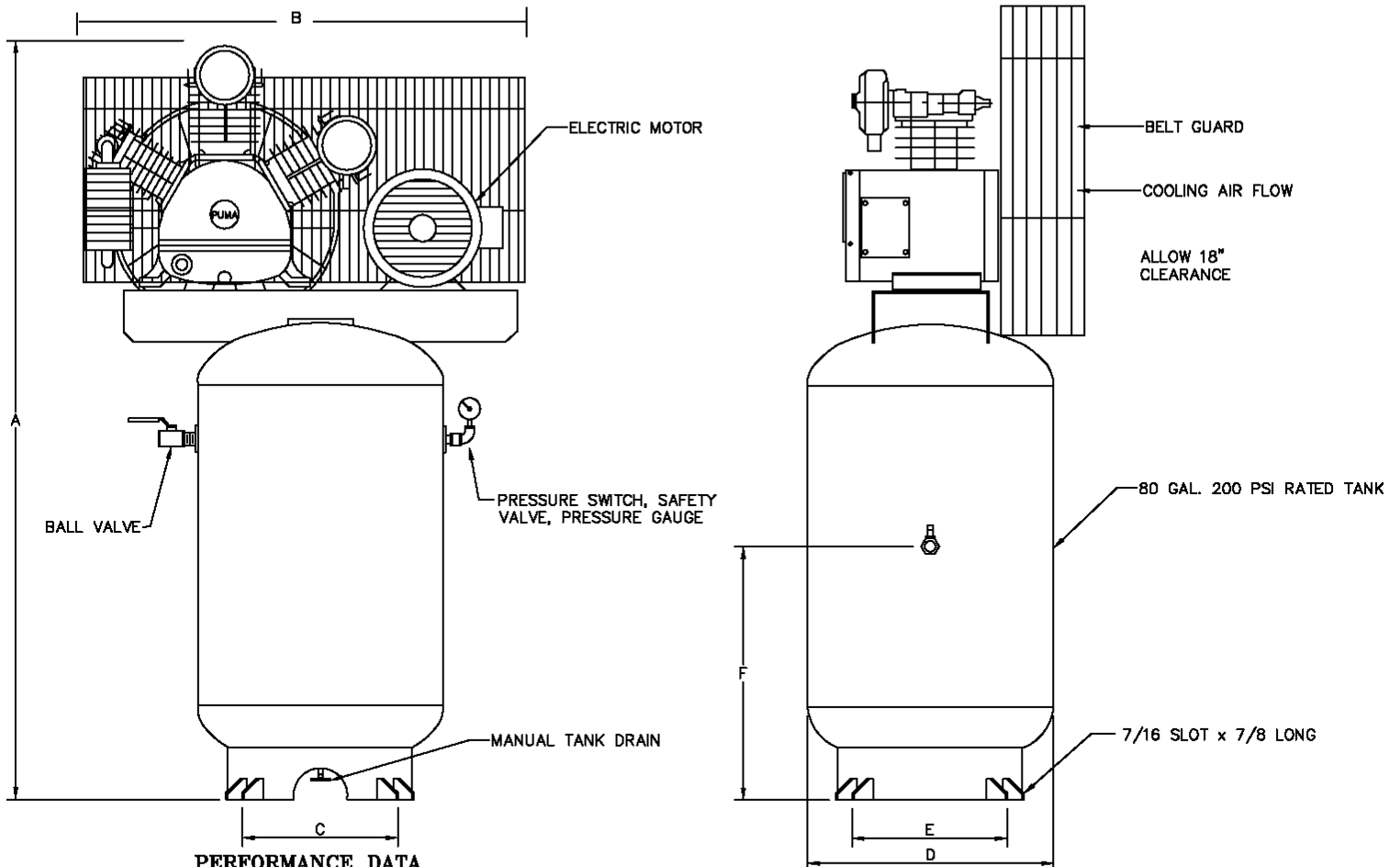

PERFORMANCE DATA

MODEL	HP	DELIVERY		PRESSURE SETTINGS		RECEIVER		COMPRESSOR			
		SCFM	L/S	PSIG	KPA	Gal US.	LITERS	PUMP	RPM	CYL	STGS
TK-10080V	10	35.3	16.66	120-150	828-1034	80	302	TK-100	845	V-3	2

DIMENSIONAL DATA (inches)

MODEL	A	B	C	D	E	F	G
TK-10080V	73	39	18	25	18	38	N/A

WT. DISTRIBUTION (Lbs)

FT.1	FT.2	FT.3	FT.4	TOTAL
208	249	132	240	829

ELECTRICAL DATA (60Hz)

APPROX. FULL LOAD AMPS						
HP.	Single Phase		Three Phase			
	110V.	220V.	200V.	230V.	460V.	575V.
10	N/A	40.8	27.5	25.0	12.5	10.0

BELT GUARD SIDE	
2	4
1	3

OMEGA AIR COMPRESSORS	INDUSTRIAL SERIES	10 HP TANK MOUNTED SIMPLEX COMPRESSOR	Print No: Dwg: Chk'd	ESJL33S-1 Scale: Not to. Wt Dist: +-5lbs
Typical only. Data & specifications may be subject to change. May not include accessory items for any particular order.			Project Reference:	