

OMEGA COMPRESSORS

For us, it's not just business. It's personal.

TE-0320

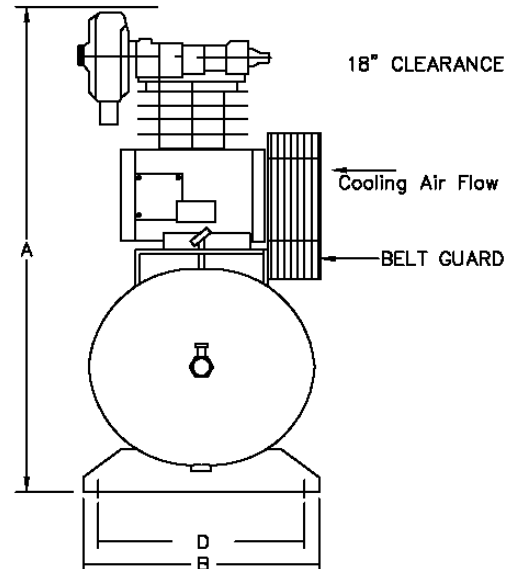
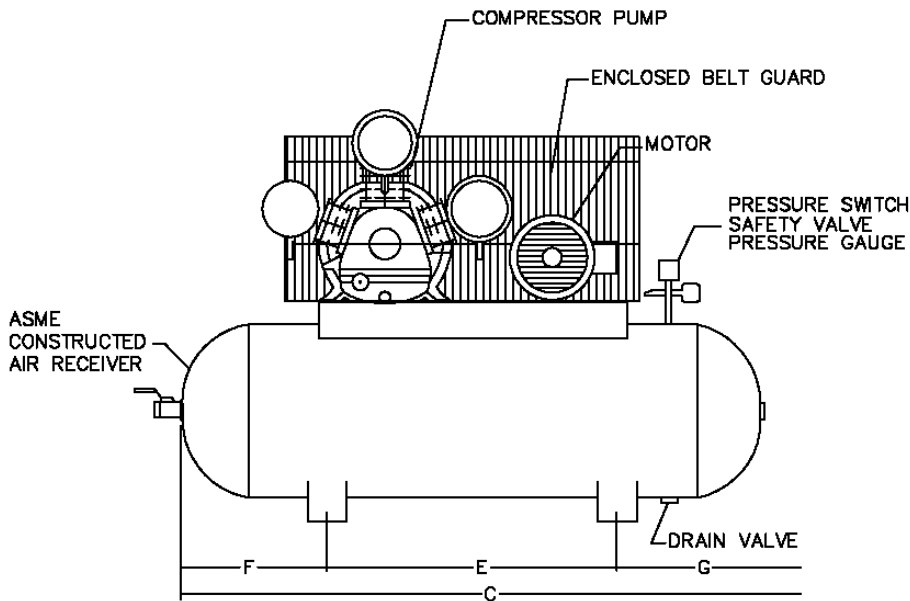

PERFORMANCE DATA

| MODEL | HP | DELIVERY | | PRESSURE SETTINGS | | RECEIVER | | COMPRESSOR | | | |
|---------|----|----------|------|-------------------|-----|----------|------------|------------|-----|-----|------|
| | | SCFM | L/S | PSIG | KPA | Gal | US. LITERS | PUMP | RPM | CYL | STGS |
| TE-0320 | 3 | 11 | 5.19 | 125 | 862 | 20 | 76 | TE-50 | 800 | 3 | 2 |

DIMENSIONAL DATA (inches)

| MODEL | A | B | C | D | E | F | G |
|---------|----|----|----|----|----|----|----|
| TE-0320 | 35 | 16 | 45 | 14 | 18 | 14 | 13 |

WT. DISTRIBUTION (Lbs)

| FT.1 | FT.2 | FT.3 | FT.4 | TOTAL |
|------|------|------|------|-------|
| 54 | 65 | 35 | 61 | 215 |

ELECTRICAL DATA (60Hz)

| HP. | APPROX. FULL LOAD AMPS | | | | | |
|-----|------------------------|-------|-------------|-------|-------|-------|
| | Single Phase | | Three Phase | | | |
| | 110V. | 220V. | 200V. | 230V. | 460V. | 575V. |
| 3 | N/A | 12.5 | 7.92 | 7.2 | 3.6 | 2.9 |

| BELT GUARD SIDE | |
|-----------------|---|
| 2 | 4 |
| 1 | 3 |

| | | | | |
|--|----------------------|---|----------------------------|--|
| OMEGA AIR COMPRESSORS | INDUSTRIAL SERIES | 3 HP TANK MOUNTED SIMPLEX COMPRESSOR | Print No: Dwg: Chk'd | ESJL33S-1 Scale: Not to. Wt Dist: +-5lbs |
| Typical only. Data & specifications may be subject to change. May not include accessory items for any particular order. | | | Project Reference: | |