

OMEGA COMPRESSORS

For us, it's not just business. It's personal.

PUK-5530G

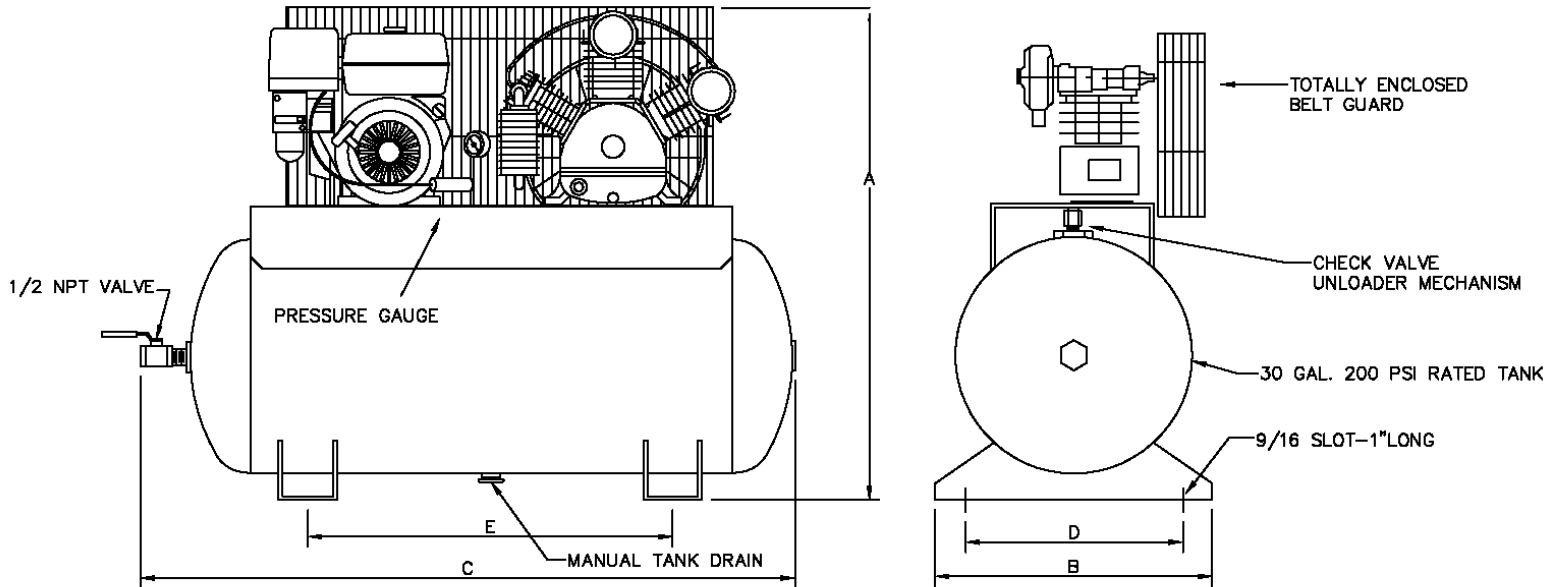

PERFORMANCE DATA

MODEL	HP	DELIVERY		PRESSURE SETTINGS		RECEIVER		COMPRESSOR			
		SCFM	L/S	PSIG	KPA	Gal US.	LITERS	PUMP	RPM	CYL	STGS
PUK-5530G	5.5	10.5	4.96	100-125	690-862	30	113	PUK-60	1100	2	1

DIMENSIONAL DATA (Inches)

MODEL	A	B	C	D	E	F	G
PUK-5530G	35	20	46	15	20.75	N/A	N/A

WT. DISTRIBUTION (Lbs)

FT.1	FT.2	FT.3	FT.4	TOTAL
57	87	47	79	270

ELECTRICAL DATA (60Hz)

HP.	APPROX. FULL LOAD AMPS					
	Single Phase			Three Phase		
	110V.	220V.	200V.	230V.	460V.	575V.
N/A	N/A	N/A	N/A	N/A	N/A	N/A

BELT GUARD SIDE

2	4
1	3

OMEGA AIR COMPRESSORS	INDUSTRIAL SERIES	5.5HP TANK MOUNTED GAS COMPRESSOR	Print No: Dwg: Chk'd	ESJL33S-1 Scale: Not to Wt Dist: +-5lbs
Typical only. Data & specifications may be subject to change. May not include accessory items for any particular order.			Project Reference:	