

OMEGA COMPRESSORS

For us, it's not just business. It's personal.

GT-200240

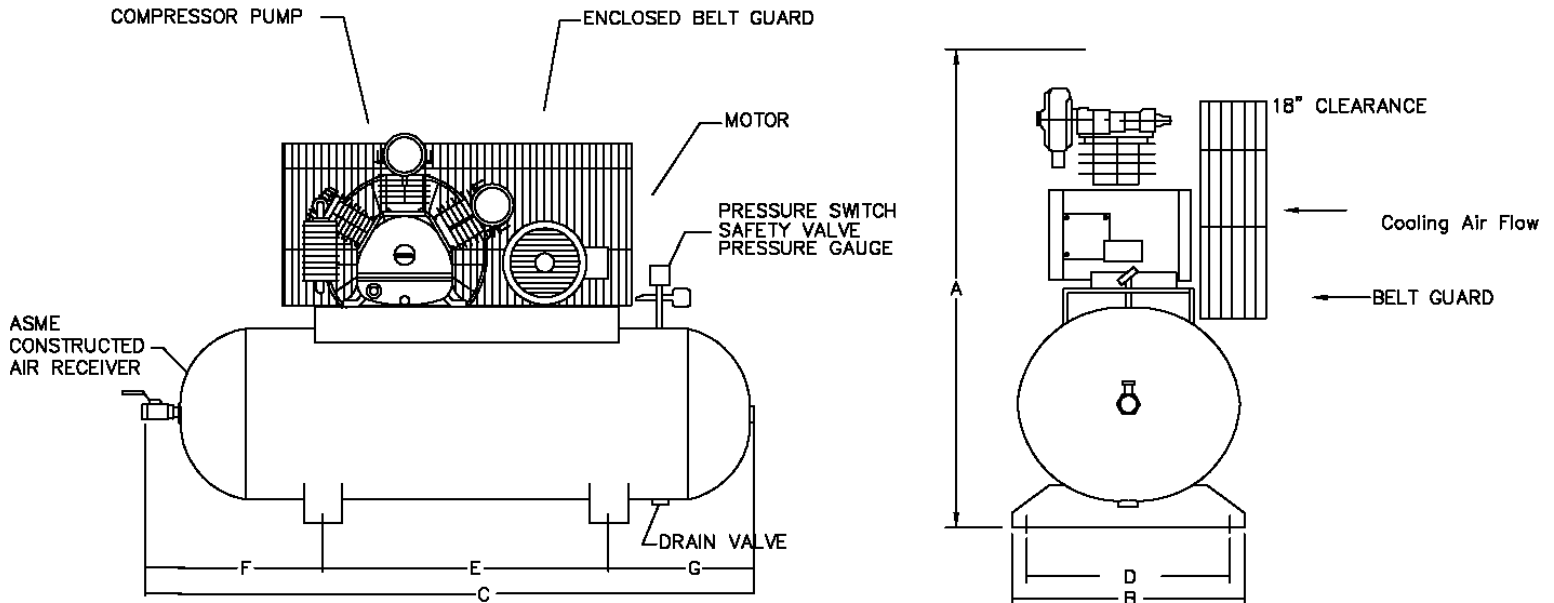

PERFORMANCE DATA

MODEL	HP	DELIVERY		PRESSURE SETTINGS		RECEIVER		COMPRESSOR			
		SCFM	L/S	PSIG	KPA	Gal	US. LITERS	PUMP	RPM	CYL	STGS
GT-200240	20	68.8	32.47	120-150	828-1034	240	907	GT-200	920	V-3	2

DIMENSIONAL DATA (inches)

MODEL	A	B	C	D	E	F	G
GT-200240	64	33	92	27.5	54	22	16

WT. DISTRIBUTION (Lbs)

FT.1	FT.2	FT.3	FT.4	TOTAL
391	475	258	448	1572

ELECTRICAL DATA (60Hz)

HP.	APPROX. FULL LOAD AMPS					
	Single Phase		Three Phase			
	110V.	220V.	200V.	230V.	460V.	575V.
20	N/A	N/A	51.8	48.0	24.0	19.2

BELT GUARD SIDE	
2	4
1	3

OMEGA AIR COMPRESSORS	INDUSTRIAL SERIES	20 HP TANK MOUNTED SIMPLEX COMPRESSOR	Print No: Dwg: Chk'd	ESJL33S-1 Scale: Not to. Wt Dist: +-5lbs
Typical only. Data & specifications may be subject to change. May not include accessory items for any particular order.			Project Reference:	