

# OMEGA COMPRESSORS

For us, it's not just business. It's personal.

GT-200120

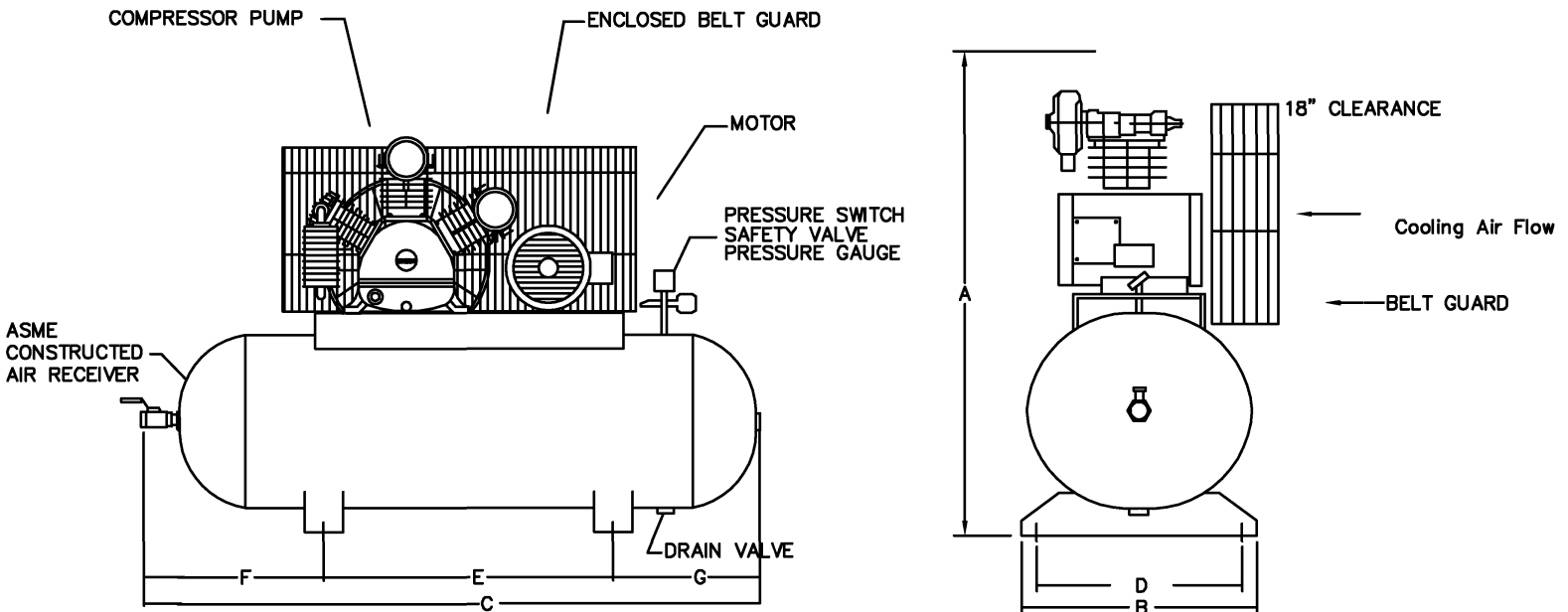

### PERFORMANCE DATA

MODEL	HP	DELIVERY		PRESSURE SETTINGS		RECEIVER		COMPRESSOR			
		SCFM	L/S	PSIG	KPA	Gal	US. LITERS	PUMP	RPM	CYL	STGS
GT-200120	20	68.8	32.47	120-150	828-1034	120	454	GT-200	920	V-3	2

### DIMENSIONAL DATA (inches)

MODEL	A	B	C	D	E	F	G
GT-200120	57	29	75	23.75	42	19.5	13.5

### WT. DISTRIBUTION (Lbs)

FT.1	FT.2	FT.3	FT.4	TOTAL
313	378	206	360	1257

### ELECTRICAL DATA (60Hz)

HP.	APPROX. FULL LOAD AMPS					
	Single Phase		Three Phase			
	110V.	220V.	200V.	230V.	460V.	575V.
20	N/A	N/A	51.8	48.0	24.0	19.2

BELT GUARD SIDE	
2	4
1	3

OMEGA AIR COMPRESSORS	INDUSTRIAL SERIES	20 HP TANK MOUNTED SIMPLEX COMPRESSOR	Print No: Dwg: Chk'd	ESJL33S-1 Scale: Not to. Wt Dist: +-5lbs
Typical only. Data & specifications may be subject to change. May not include accessory items for any particular order.			Project Reference:	