

OMEGA COMPRESSORS

For us, it's not just business. It's personal.

GT-150240

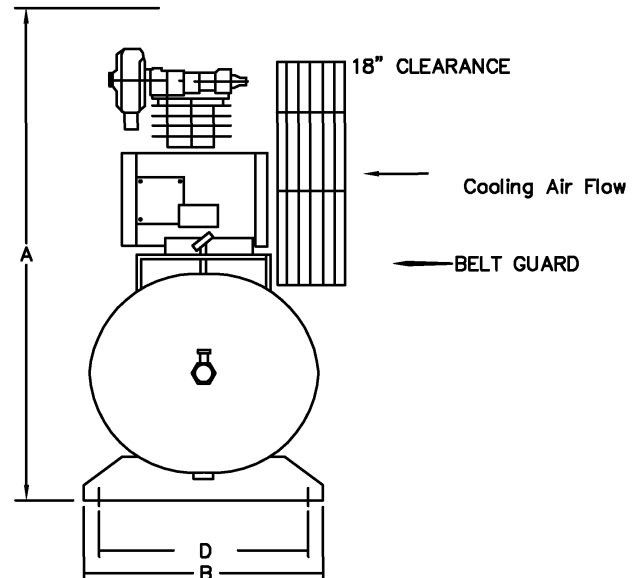
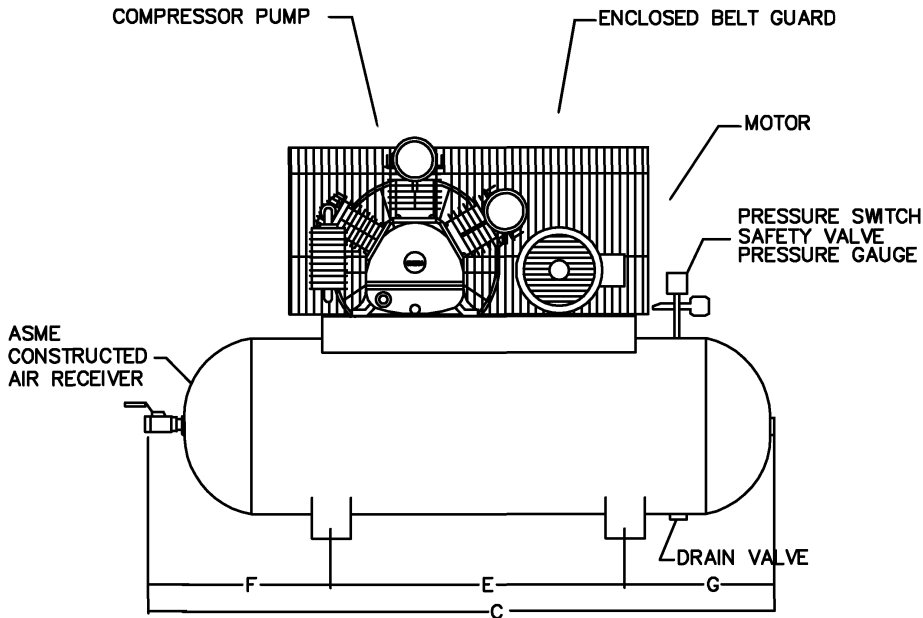

PERFORMANCE DATA

| MODEL | HP | DELIVERY | | PRESSURE SETTINGS | | RECEIVER | | COMPRESSOR | | | |
|-----------|----|----------|-------|-------------------|----------|----------|------------|------------|-----|-----|------|
| | | SCFM | L/S | PSIG | KPA | Gal | US. LITERS | PUMP | RPM | CYL | STGS |
| GT-150240 | 15 | 52 | 24.54 | 120-150 | 828-1034 | 120 | 454 | GT-200 | 668 | V-3 | 2 |

DIMENSIONAL DATA (inches)

| MODEL | A | B | C | D | E | F | G |
|-----------|----|----|----|------|----|----|----|
| GT-150240 | 64 | 33 | 92 | 27.5 | 54 | 22 | 16 |

WT. DISTRIBUTION (Lbs)

| FT.1 | FT.2 | FT.3 | FT.4 | TOTAL |
|------|------|------|------|-------|
| 380 | 460 | 250 | 437 | 1527 |

ELECTRICAL DATA (60Hz)

| APPROX. FULL LOAD AMPS | | | | | | |
|------------------------|--------------|-------|-------------|-------|-------|-------|
| HP. | Single Phase | | Three Phase | | | |
| | 110V. | 220V. | 200V. | 230V. | 460V. | 575V. |
| 15 | N/A | N/A | 40.6 | 37.6 | 18.8 | 15.0 |

| BELT GUARD SIDE | |
|-----------------|---|
| 2 | 4 |
| 1 | 3 |

| | | | | |
|--|----------------------|--|----------------------------|--|
| OMEGA AIR COMPRESSORS | INDUSTRIAL SERIES | 15 HP TANK MOUNTED SIMPLEX COMPRESSOR | Print No: Dwg: Chk'd | ESJL33S-1 Scale: Not to. Wt Dist: +-5lbs |
| Typical only. Data & specifications may be subject to change. May not include accessory items for any particular order. | | | Project Reference: | |