

OMEGA COMPRESSORS

For us, it's not just business. It's personal.

FS-0330

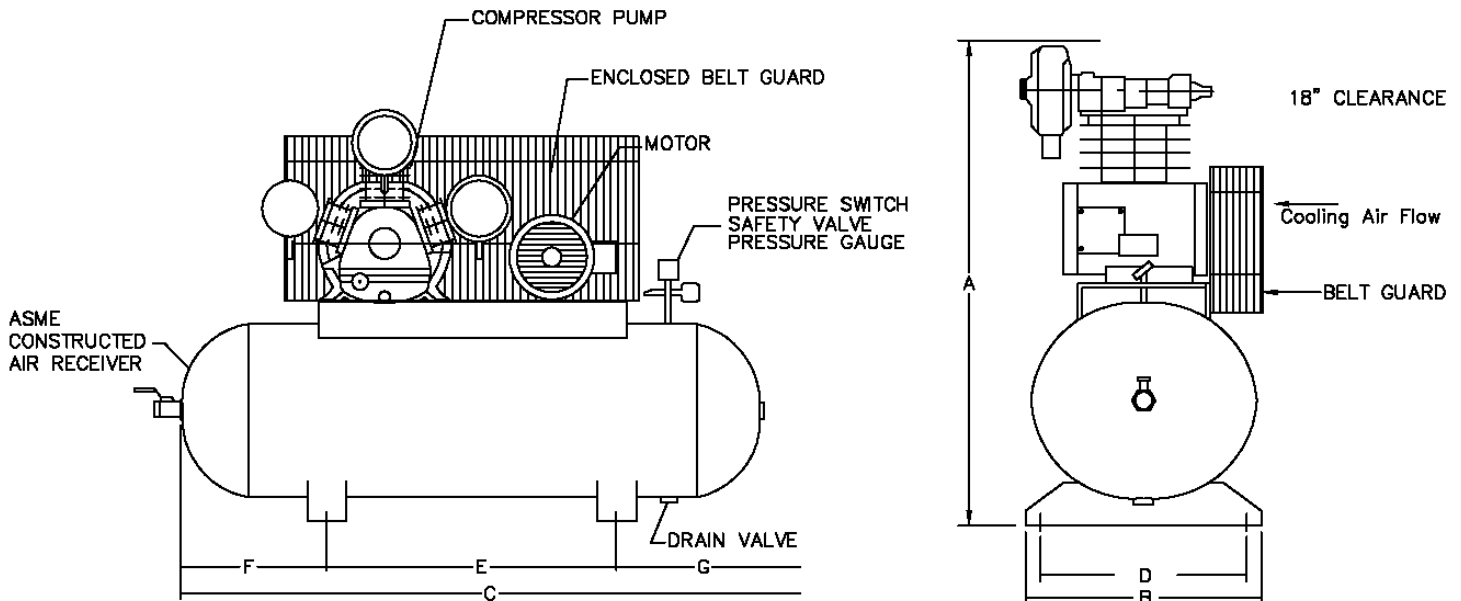

PERFORMANCE DATA

MODEL	HP	DELIVERY		PRESSURE SETTINGS		RECEIVER		COMPRESSOR			
		SCFM	L/S	PSIG	KPA	Gal US.	LITERS	PUMP	RPM	CYL	STGS
FS-0330	3	15.3	7.22	30 - 50	207 - 345	30	113	CK-40	843	3	1

DIMENSIONAL DATA (inches)

MODEL	A	B	C	D	E	F	G
FS-0330	37	19	49	15	18	16	15

WT. DISTRIBUTION (Lbs)

FT.1	FT.2	FT.3	FT.4	TOTAL
63	75	41	72	251

ELECTRICAL DATA (60Hz)

HP.	APPROX. FULL LOAD AMPS					
	Single Phase		Three Phase			
	110V.	220V.	200V.	230V.	460V.	575V.
3	N/A	12.5	7.92	7.2	3.6	2.9

BELT GUARD SIDE	
2	4
1	3

SYSTEM SIZE - 1,440gals. in system to be pumped to 35psi in 30 minutes.

OMEGA AIR COMPRESSORS	SPRINKLER SERIES	3 HP TANK MOUNTED SIMPLEX COMPRESSOR	Print No: Dwg: Chk'd	ESJL33S-1 Scale: Not to. Wt Dist: +-5lbs
-----------------------	------------------	--------------------------------------	----------------------------	--

Typical only. Data & specifications may be subject to change. May not include accessory items for any particular order.

Project Reference: