

# OMEGA COMPRESSORS

For us, it's not just business. It's personal.

CC-7580

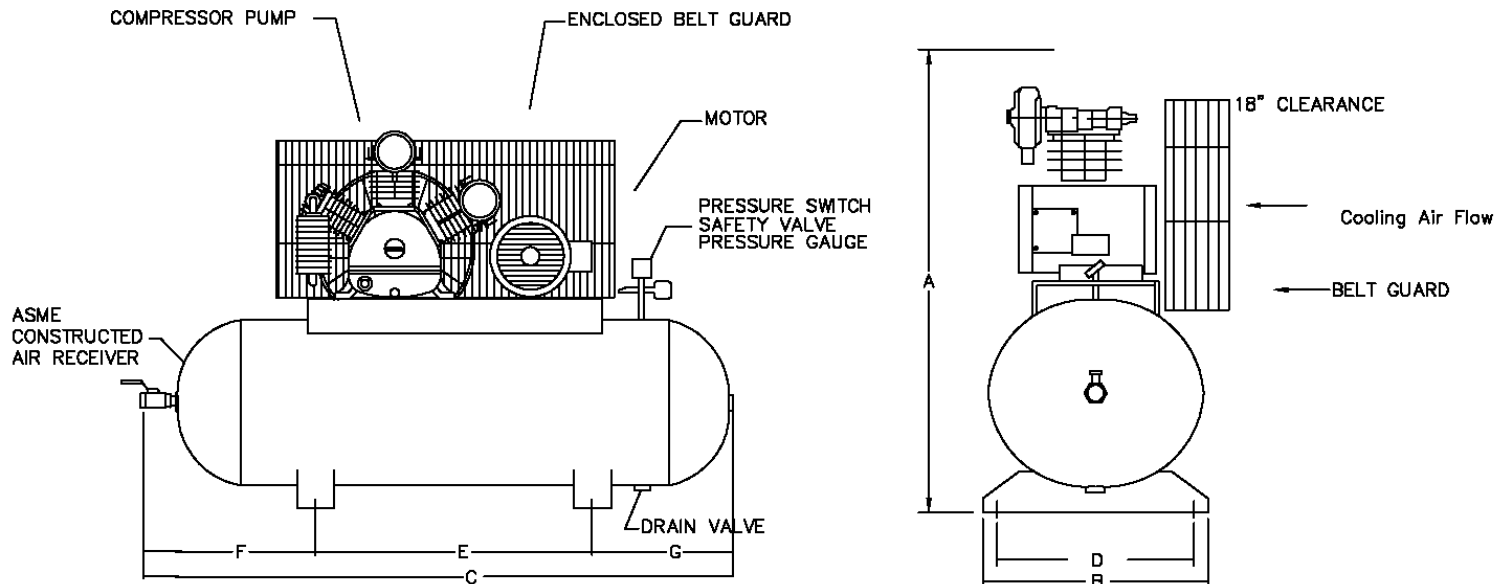

### PERFORMANCE DATA

MODEL	HP	DELIVERY		PRESSURE SETTINGS		RECEIVER		COMPRESSOR			
		SCFM	L/S	PSIG	KPA	Gal	US. LITERS	PUMP	RPM	CYL	STGS
CC-7580	7.5	28.5	13.45	70-90	483-621	80	302	TK-100	630	V-3	2

### DIMENSIONAL DATA (inches)

MODEL	A	B	C	D	E	F	G
CC-7580	50	22	71	18.75	36	21	14

### WT. DISTRIBUTION (Lbs)

FT.1	FT.2	FT.3	FT.4	TOTAL
179	217	118	207	721

### ELECTRICAL DATA (60Hz)

HP.	APPROX. FULL LOAD AMPS					
	Single Phase		Three Phase			
	110V.	220V.	200V.	230V.	460V.	575V.
7.5	N/A	36.0	21.2	19.6	9.8	7.8

BELT GUARD SIDE	
2	4
1	3

OMEGA AIR COMPRESSORS	HVAC SERIES	7.5 HP TANK MOUNTED SIMPLEX COMPRESSOR	Print No: Dwg: Chk'd	ESJL33S-1 Scale: Not to. Wt Dist: +-5lbs
Typical only. Data & specifications may be subject to change. May not include accessory items for any particular order.			Project Reference:	