

OMEGA COMPRESSORS

For us, it's not just business. It's personal.

CC-250000

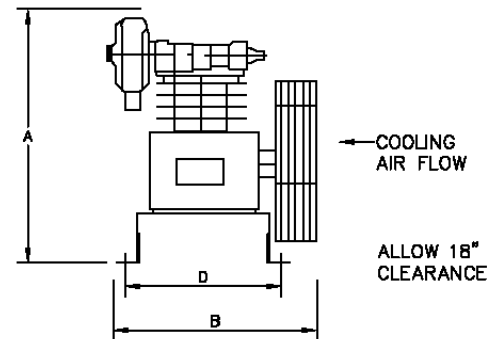
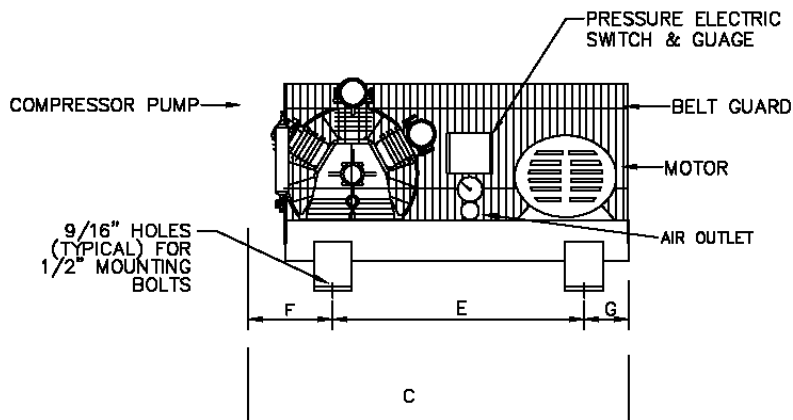

PERFORMANCE DATA

MODEL	HP	DELIVERY		PRESSURE SETTINGS		RECEIVER		COMPRESSOR			
		SCFM	L/S	PSIG	KPA	Gal	US. LITERS	PUMP	RPM	CYL	STGS
CC-250000	25	102.0	48.14	70 - 90	483 - 621	N/A	N/A	TK-300	720	4	2

DIMENSIONAL DATA (inches)

MODEL	A	B	C	D	E	F	G
CC-250000	38	36	64	18	32	18	14

WT. DISTRIBUTION (Lbs)

FT.1	FT.2	FT.3	FT.4	TOTAL
322	382	204	366	1274

ELECTRICAL DATA (60Hz)

HP.	APPROX. FULL LOAD AMPS					
	Single Phase		Three Phase			
	110V.	220V.	200V.	230V.	460V.	575V.
25	N/A	N/A	64.4	59.6	29.8	23.8

BELT GUARD SIDE	
2	4
1	3

OMEGA AIR COMPRESSORS	INDUSTRIAL SERIES	25HP BASE MOUNTED HVAC SERIES	Print No: Dwg: Chk'd	ESJL33S-1 Scale: Not to. Wt Dist: +-5lbs
Typical only. Data & specifications may be subject to change. May not include accessory items for any particular order.			Project Reference:	