

OMEGA COMPRESSORS

For us, it's not just business. It's personal.

CC-0230

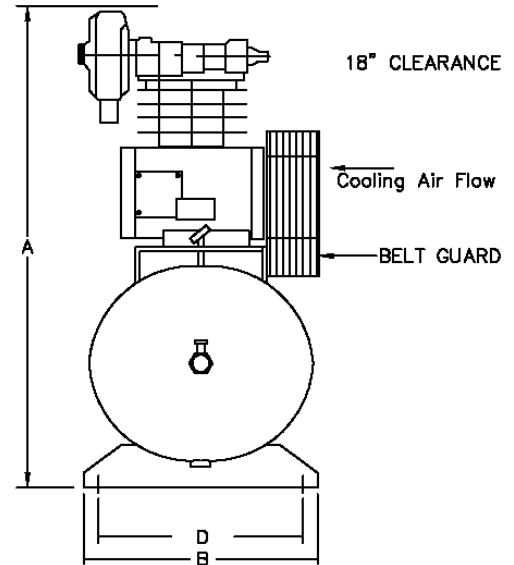
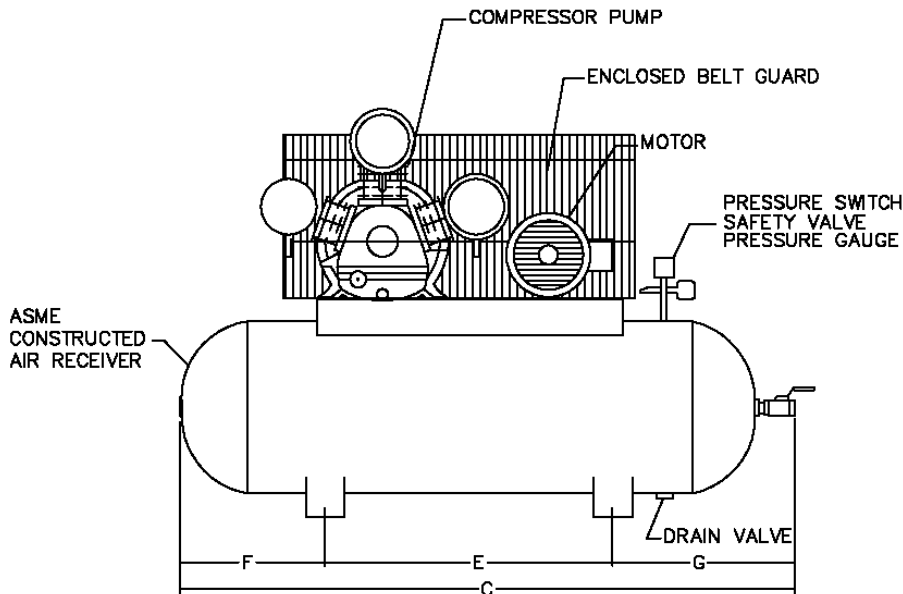

PERFORMANCE DATA

MODEL	HP	DELIVERY		PRESSURE SETTINGS		RECEIVER		COMPRESSOR			
		SCFM	L/S	PSIG	KPA	Gal	US. LITERS	PUMP	RPM	CYL	STGS
CC-0230	2	9.2	4.34	70-90	483-620	30	113	CK-40	544	3	1

DIMENSIONAL DATA (inches)

MODEL	A	B	C	D	E	F	G
CC-0230	37.25	19	50	15	18	16	16

WT. DISTRIBUTION (Lbs)

FT.1	FT.2	FT.3	FT.4	TOTAL
58	73	58	72	261

ELECTRICAL DATA (60Hz)

HP.	APPROX. FULL LOAD AMPS					
	Single Phase		Three Phase			
	110V.	220V.	200V.	230V.	460V.	575V.
2	25.6	12.8	6.6	6.0	3.0	2.4

BELT GUARD SIDE	
2	4
1	3

OMEGA AIR COMPRESSORS	HVAC SERIES	2 HP TANK MOUNTED SIMPLEX COMPRESSOR	Print No: Dwg: Chk'd	ESJL33S-1 Scale: Not to. Wt Dist: +-5lbs
--------------------------	----------------	---	----------------------------	--

Typical only. Data & specifications may be subject to change.
May not include accessory items for any particular order.

Project Reference: