

OMEGA COMPRESSORS

For us, it's not just business. It's personal.

CC-01560

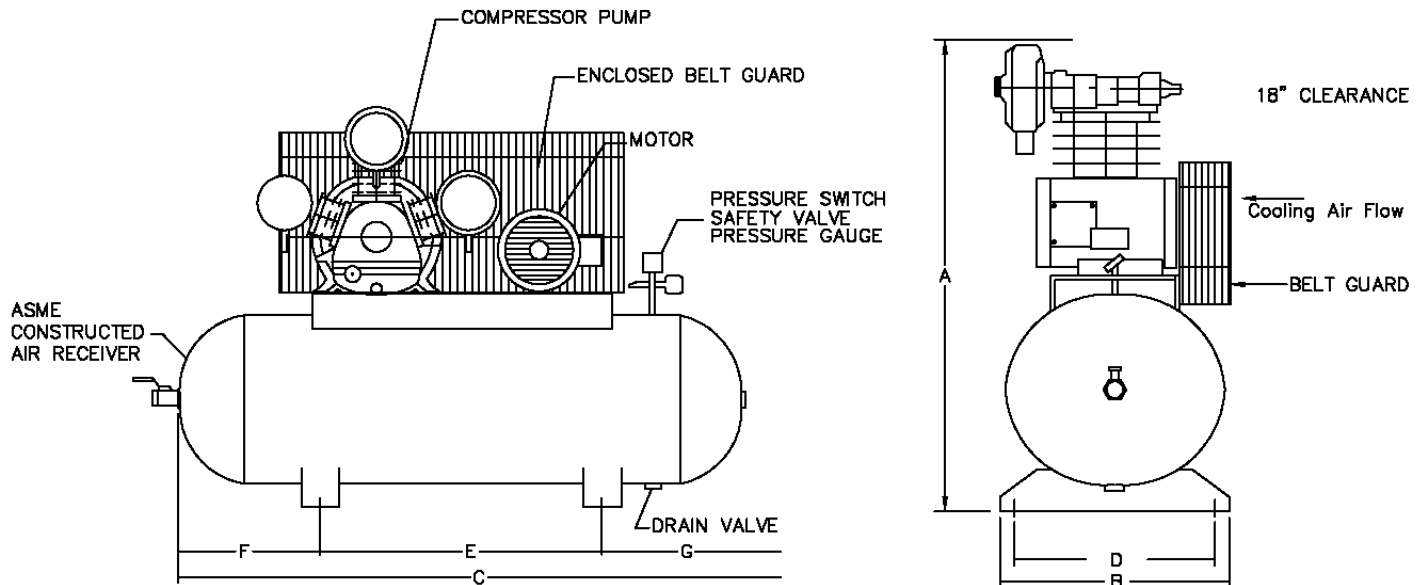

PERFORMANCE DATA

MODEL	HP	DELIVERY		PRESSURE SETTINGS		RECEIVER		COMPRESSOR			
		SCFM	L/S	PSIG	KPA	Gal	US. LITERS	PUMP	RPM	CYL	STGS
CC-01560	1.5	6.7	3.16	70-90	483-620	60	227	CK-40	420	3	1

DIMENSIONAL DATA (inches)

MODEL	A	B	C	D	E	F	G
CC-01560	43	22	54	18.75	24	18	12

WT. DISTRIBUTION (Lbs)

FT.1	FT.2	FT.3	FT.4	TOTAL
76	95	75	93	339

ELECTRICAL DATA (60Hz)

HP.	APPROX. FULL LOAD AMPS					
	Single Phase		Three Phase			
	110V.	220V.	200V.	230V.	460V.	575V.
1.5	18.0	9.0	4.8	4.4	2.2	2.0

BELT GUARD SIDE	
2	4
1	3

OMEGA AIR COMPRESSORS	HVAC SERIES	1.5 HP TANK MOUNTED SIMPLEX COMPRESSOR	Print No: Dwg: Chk'd	ESJL33S-1 Scale: Not to. Wt Dist: +-5lbs
Typical only. Data & specifications may be subject to change. May not include accessory items for any particular order.			Project Reference:	