

OMEGA COMPRESSORS

For us, it's not just business. It's personal.

CC-0153

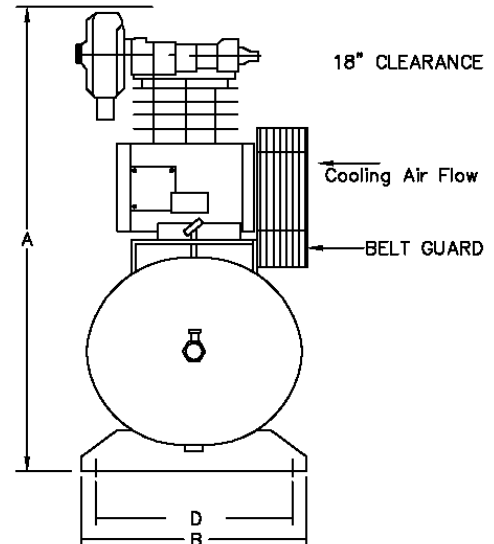
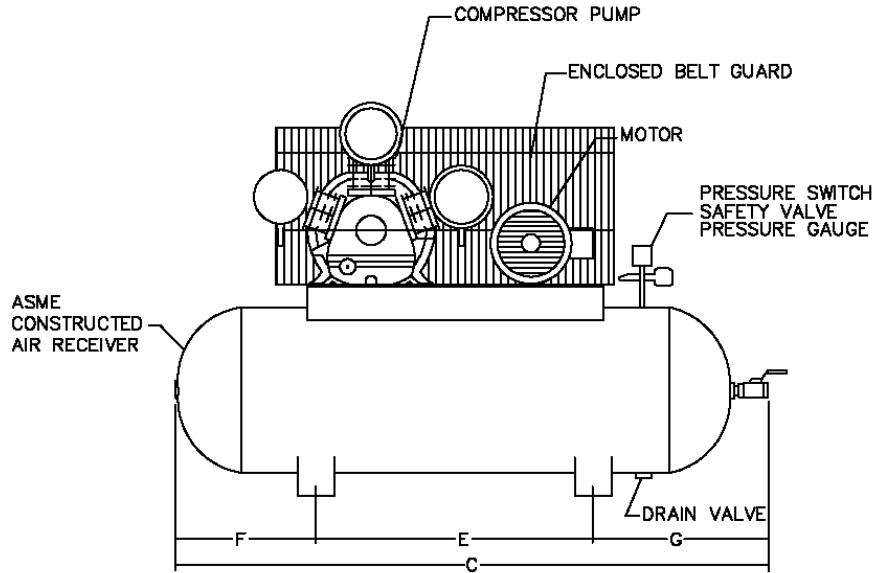

PERFORMANCE DATA

MODEL	HP	DELIVERY		PRESSURE SETTINGS		RECEIVER		COMPRESSOR			
		SCFM	L/S	PSIG	KPA	Gal US.	LITERS	PUMP	RPM	CYL	STGS
CC-01530	1.5	6.7	3.16	70-90	483-620	30	113	CK-40	420	3	1

DIMENSIONAL DATA (inches)

MODEL	A	B	C	D	E	F	G
CC-01530	37.25	19	50	15	18	16	16

WT. DISTRIBUTION (lbs)

FT.1	FT.2	FT.3	FT.4	TOTAL
58	73	58	72	261

ELECTRICAL DATA (60Hz)

HP.	APPROX. FULL LOAD AMPS					
	Single Phase		Three Phase			
	110V.	220V.	200V.	230V.	460V.	575V.
1.5	18.0	9.0	4.8	4.4	2.2	2.0

BELT GUARD SIDE	
2	4
1	3

OMEGA AIR COMPRESSORS	HVAC SERIES	1.5HP TANK MOUNTED SIMPLEX COMPRESSOR	Print No: Dwg: Chk'd	ESJL33S-1 Scale: Not to. Wt Dist: +-5lbs
Typical only. Data & specifications may be subject to change. May not include accessory items for any particular order.			Project Reference:	