

OMEGA COMPRESSORS

For us, it's not just business. It's personal.

CC-0130

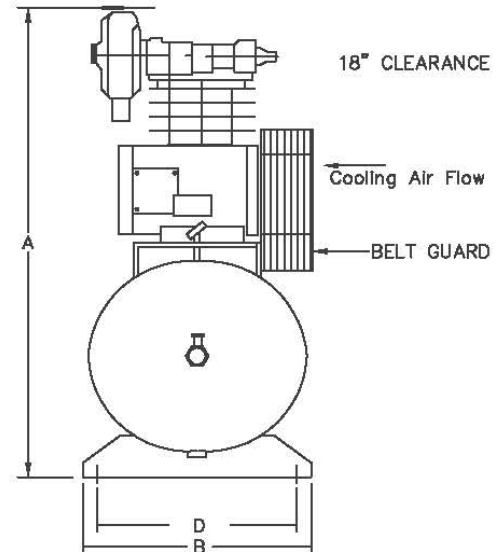
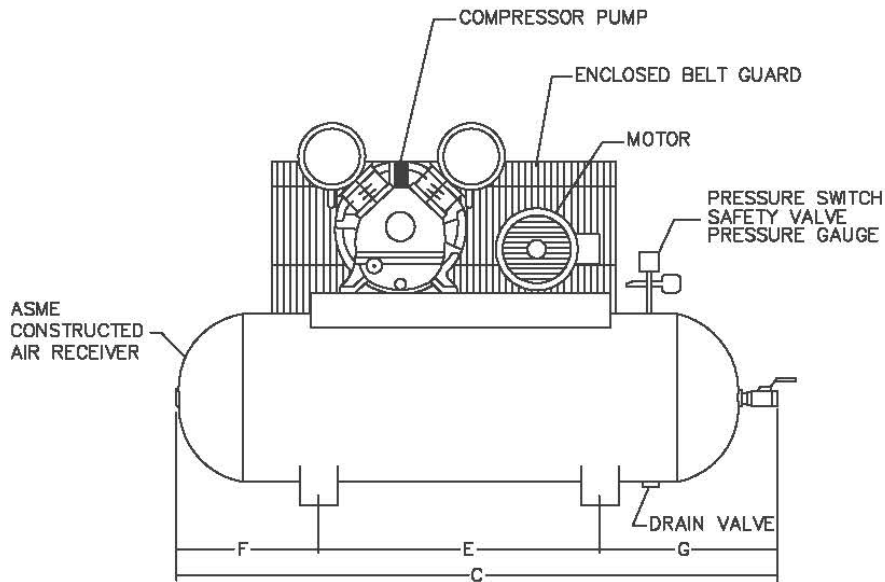

PERFORMANCE DATA

MODEL	HP	DELIVERY		PRESSURE SETTINGS		RECEIVER		COMPRESSOR			
		SCFM	L/S	PSIG	KPA	Gal US.	LITERS	PUMP	RPM	CYL	STGS
CC-0130	1	4.5	2.12	70-90	483-620	30	113.4	PK-50	714	2	1

DIMENSIONAL DATA (inches)

MODEL	A	B	C	D	E	F	G
CC-0130	33	19	50	15	18	16	16

WT. DISTRIBUTION (Lbs)

FT.1	FT.2	FT.3	FT.4	TOTAL
55	70	55	71	251

ELECTRICAL DATA (60Hz)

HP.	APPROX. FULL LOAD AMPS					
	Single Phase			Three Phase		
	110V.	220V.	200V.	230V.	460V.	575V.
1	16.1	8.3	3.8	3.4	1.7	1.4

BELT GUARD SIDE	
2	4
1	3

OMEGA AIR COMPRESSORS	HVAC SERIES	1 HP TANK MOUNTED SIMPLEX COMPRESSOR	Print No: Dwg: Chk'd	ESJL33S-1 Scale: Not to. Wt Dist: +-5lbs
Typical only. Data & specifications may be subject to change. May not include accessory items for any particular order.			Project Reference:	