

OMEGA COMPRESSORS

For us, it's not just business. It's personal.

BF-7580

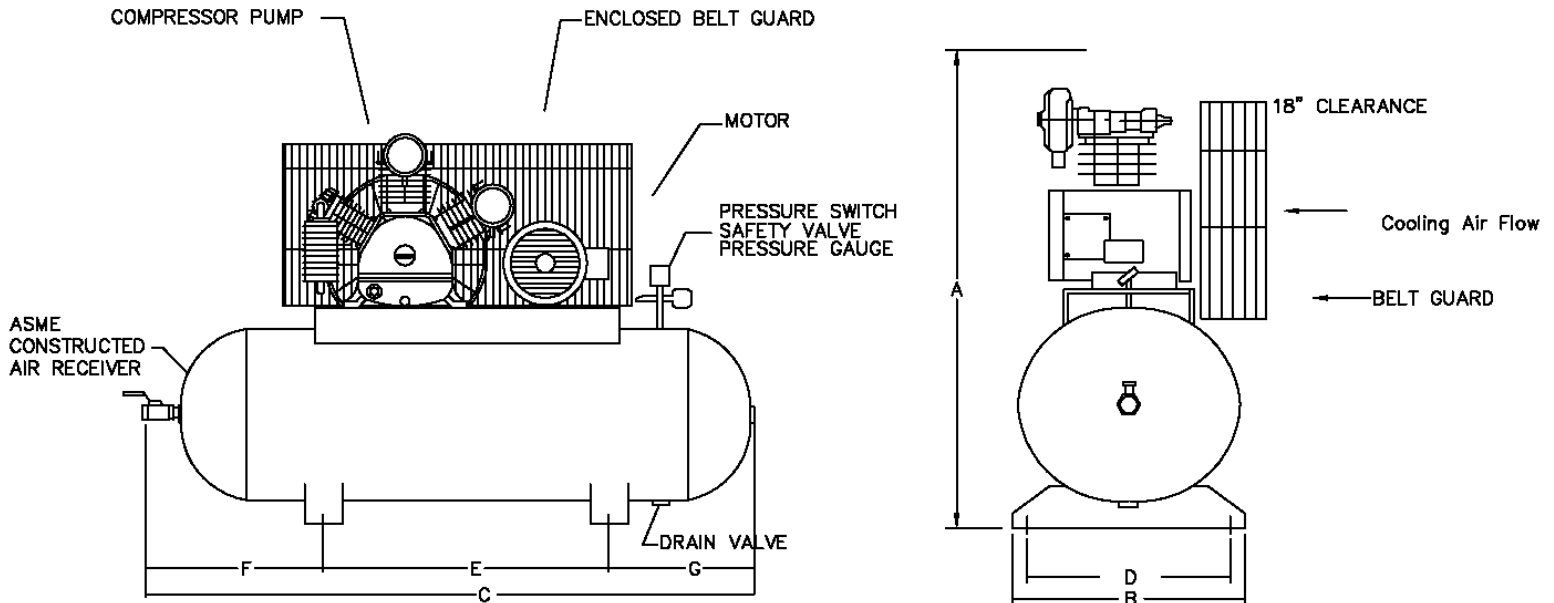

PERFORMANCE DATA

MODEL	HP	DELIVERY		PRESSURE SETTINGS		RECEIVER		COMPRESSOR			
		SCFM	L/S	PSIG	KPA	Gal	US. LITERS	PUMP	RPM	CYL	STGS
BF-7580	7.5	22.0	10.38	70-90	483-621	80	302	BF-100	750	V-3	1

DIMENSIONAL DATA (inches)

MODEL	A	B	C	D	E	F	G
BF-7580	47	22	71	18.75	36	21	14

WT. DISTRIBUTION (Lbs)

FT.1	FT.2	FT.3	FT.4	TOTAL
151	184	99	175	609

ELECTRICAL DATA (60Hz)

APPROX. FULL LOAD AMPS						
HP.	Single Phase		Three Phase			
	110V.	220V.	200V.	230V.	460V.	575V.
7.5	N/A	36.0	21.6	19.6	9.8	7.8

BELT GUARD SIDE	
2	4
1	3

OMEGA AIR COMPRESSORS	OIL LESS SERIES	7.5 HP TANK MOUNTED OIL LESS COMPRESSOR	Print No: Dwg: Chk'd	ESJL33S-1 Scale: Not to. Wt Dist: +-5lbs
--------------------------	--------------------	--	----------------------------	--

Typical only. Data & specifications may be subject to change.
May not include accessory items for any particular order.

Project Reference: