

OMEGA COMPRESSORS

For us, it's not just business. It's personal.

BF-75120

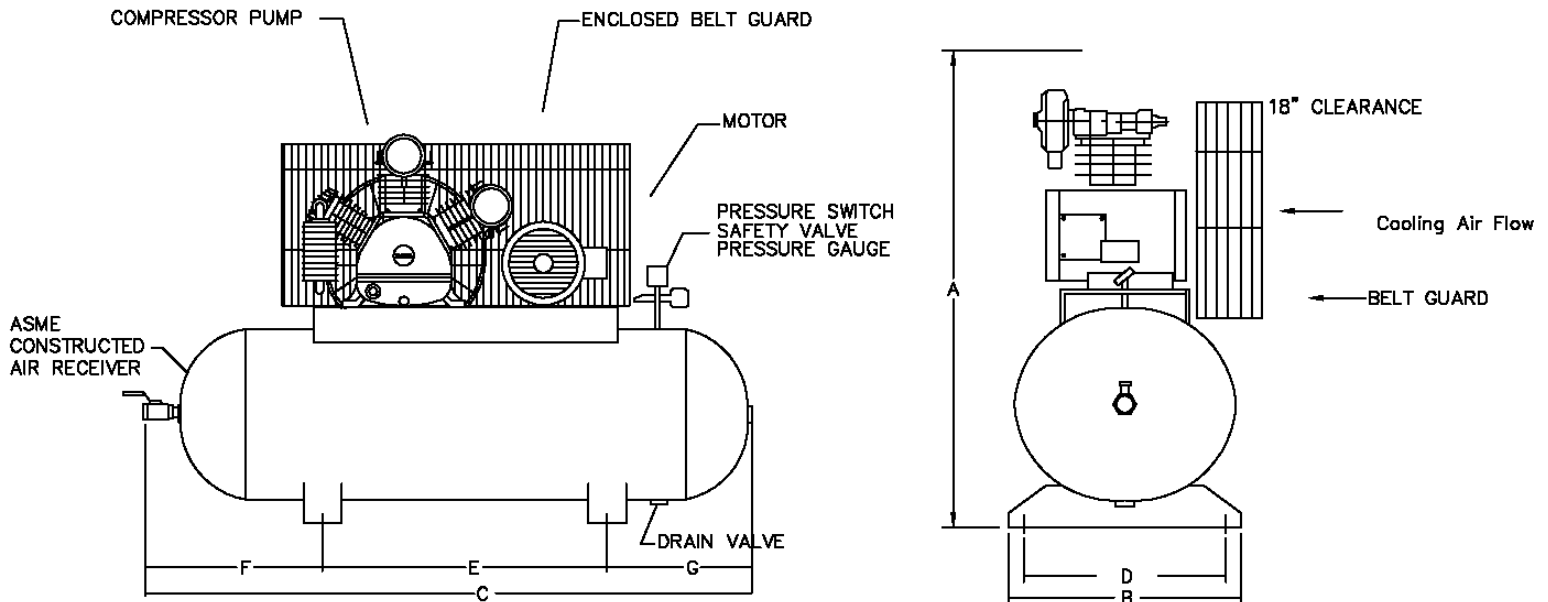

PERFORMANCE DATA

MODEL	HP	DELIVERY		PRESSURE SETTINGS		RECEIVER		COMPRESSOR			
		SCFM	L/S	PSIG	KPA	Gal	US. LITERS	PUMP	RPM	CYL	STGS
BF-75120	7.5	23	10.85	70-90	483-621	120	454	BF-100	750	V-3	1

DIMENSIONAL DATA (inches)

MODEL	A	B	C	D	E	F	G
BF-75120	54	27	75.5	23.75	42	19.5	14

WT. DISTRIBUTION (lbs)

FT.1	FT.2	FT.3	FT.4	TOTAL
213	259	140	245	857

ELECTRICAL DATA (60Hz)

HP.	APPROX. FULL LOAD AMPS					
	Single Phase		Three Phase			
	110V.	220V.	200V.	230V.	460V.	575V.
7.5	N/A	36.0	21.6	19.6	9.8	7.8

BELT GUARD SIDE	
2	4
1	3

OMEGA AIR COMPRESSORS	OIL LESS SERIES	HP TANK MOUNTED OIL LESS COMPRESSOR	Print No: Dwg: Chk'd	ESJL33S-1 Scale: Not to. Wt Dist: +-5lbs
--------------------------	--------------------	----------------------------------------	----------------------------	------------------------------------------------

Typical only. Data & specifications may be subject to change.
May not include accessory items for any particular order.

Project Reference: