

# OMEGA COMPRESSORS

For us, it's not just business. It's personal.

BF-50120

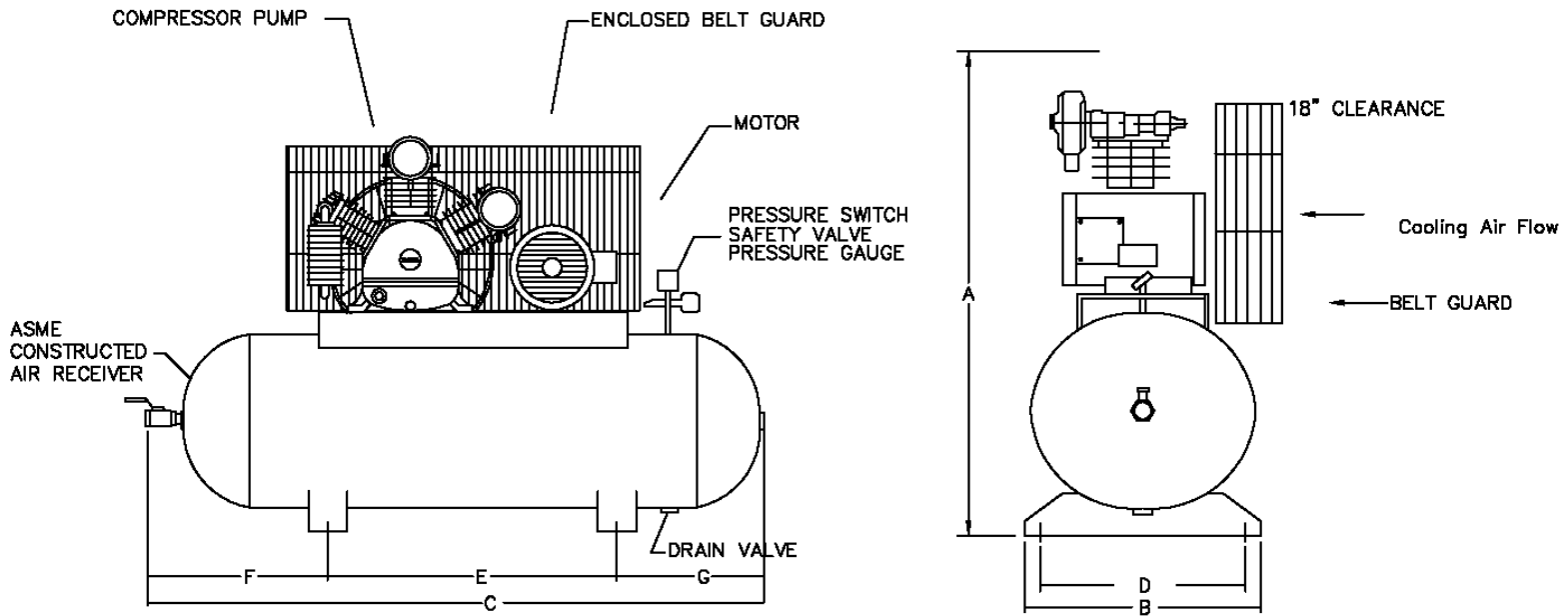

### PERFORMANCE DATA

MODEL	HP	DELIVERY		PRESSURE SETTINGS		RECEIVER		COMPRESSOR			
		SCFM	L/S	PSIG	KPA	Gal US.	LITERS	PUMP	RPM	CYL	STGS
BF-50120	5	18	8.5	70-90	483-621	120	454	BF-50	696	V-3	1

### DIMENSIONAL DATA (inches)

MODEL	A	B	C	D	E	F	G
BF-50120	48	27	75.5	23.75	42	19.5	14

### WT. DISTRIBUTION (Lbs)

FT.1	FT.2	FT.3	FT.4	TOTAL
197	238	130	228	793

### ELECTRICAL DATA (60Hz)

HP.	APPROX. FULL LOAD AMPS					
	Single Phase			Three Phase		
	110V.	220V.	200V.	230V.	460V.	575V.
5	N/A	21.05	15.8	13.8	6.9	5.5

BELT GUARD SIDE	
2	4
1	3

<b>OMEGA AIR COMPRESSORS</b>	<b>OIL LESS SERIES</b>	<b>HP TANK MOUNTED OIL LESS COMPRESSOR</b>	Print No: Dwg: Chk'd	<b>ESJL33S-1</b> Scale: Not to. Wt Dist: +-5lbs
Typical only. Data & specifications may be subject to change. May not include accessory items for any particular order.			Project Reference:	